

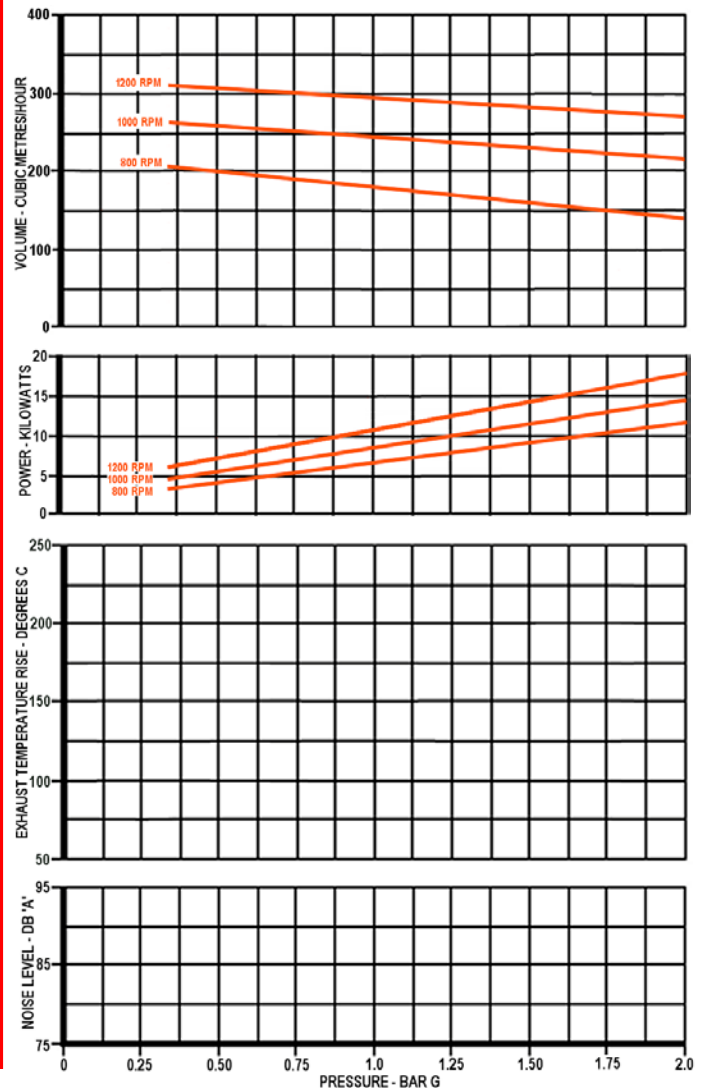

Air Performance Figures



Materials of Construction

Component	Material Specification
Cylinder	Grey Cast Iron EN-GJL-200 / EN-JL-1030 (EN1561)
Coverplates	Grey Cast Iron EN-GJL-200 / EN-JL-1030 (EN1561)
Rotor / Shaft	S.G. Iron EN-GJS-400-15 / EN-JS-1030 (EN1563)
End Caps	Grey Cast Iron EN-GJL-200 / EN-JL-1030 (EN1561)
Seal Sleeves	Grey Cast Iron EN-GJL-200 / EN-JL-1030 (EN1561)
Blades	Non-Asbestos Resin Bonded Fabric
Roller Bearing – Rear End	Single row, cylindrical roller with metal cage, 1 loose inner flange. Clearance - Normal
Roller Bearing – Drive End	Single row, cylindrical roller with metal cage. Clearance - Normal
Lip Seals	Steel cased, Viton
Mechanical Seals	Stainless Steel rings & spring, carbon face, S.G. Iron seat, Viton bellows & O-Ring

SPEED

Maximum Speed	-	1600	RPM
Minimum Speed	-	700	RPM

TEMPERATURE

Max. Inlet Temp.	-	40	°C
------------------	---	----	----

INERTIA

Moment Of Inertia	-	0.180	Kgm ²
-------------------	---	-------	------------------

WEIGHT

Approx.	-	134	kgs
---------	---	-----	-----

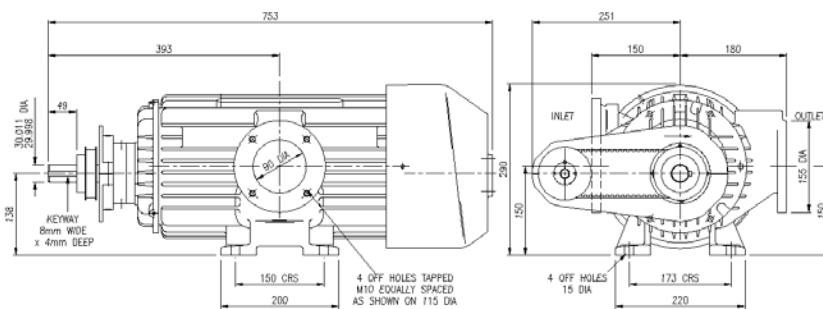

LUBRICATION

Bearings and blades lubricated using SHELL TURBO T68 oil

BEARING ARRANGEMENT

Roller bearing both ends, NU and NUP series giving approximate life values of drive end 40000 hours and rear end 57000 hours.